

Cares approval TA1-A&B 5083

Gripkoppeling

CARES Technical Approval Report TA1-A&B 5083



Issue 3

Electronic Copy www.carescertification.com

Leviat
A CRH COMPANY

Ancon MBT ET and MBT Transition Couplers

Assessment of the
Ancon MBT ET and
MBT Transition Coupler
Product and Quality
System for Production



Validate with the
CARES Cloud App

Product

Ancon MBT ET and MBT Transition Couplers for reinforcing steel

Product approval held by:

Leviat
President Way, President Park
Sheffield S4 7UR
Tel: +44 (0) 114 275 5224
Fax: +44 (0) 114 276 8543
Email: info.ancon.uk@leviat.com
Web: www.ancon.uk@leviat.com

1 Product Summary

Ancon MBT ET in the size range 10mm - 40mm and MBT Transition Couplers in the size range 12mm - 40mm are for the mechanical connection of deformed high yield carbon steel bars for the reinforcement of concrete complying with the requirements of BS4449 grades B500B and B500C as detailed in tables 1 and 2.

1.1 Scope of Application

Ancon MBT ET in the size range 10mm - 40mm and MBT Transition Couplers in the size range 12mm - 40mm have been evaluated for use as follows:

- a) In accordance with CARES Appendix TA1-A: and BS8597 tested in tension and compression with grade B500B and B500C reinforcement. CARES TA1-A meets the requirements of the Manual of Contract Documents for Highway Works (MCHW) Vol 1 Specification for Highways Works Series 1700 Structural Concrete and in particular clause 1716 part 2.
- b) In accordance with CARES Appendix TA1-B and BS8597 tested in tension and compression with grades B500B and B500C reinforcement.

1.2 Design Considerations

BS8110 Clause 3.12.8.9 Laps and Joints states "Connections transferring stress may be lapped, welded or joined with mechanical devices. They should be placed, if possible, away from points of high stress and should preferably be staggered". However, BS8110 Clause 3.12.8.16.2 Bars in tension states "The only acceptable form of full-strength butt joint for a bar in tension comprises a mechanical coupler" satisfying specified slip and tensile strength criteria.

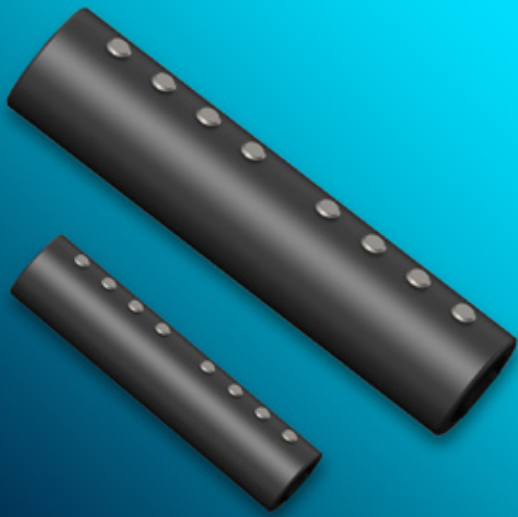

Eurocode 2, Clause 8.7 Laps and mechanical couplers 8.7.1 General (1)P “Forces are transmitted from one bar to another by:

- lapping of bars, with or without bends or hooks;
- welding;
- mechanical devices assuring load transfer in tension-compression or in compression only.”

Clause 8.8 Additional rules for large diameter bars goes on to state that “Splitting forces are higher and dowel action is greater with the use of large diameter bars. Such bars should be anchored with mechanical devices.”

The specified cover for fire resistance and durability should be provided to the coupler sleeve. All couplers have been designed with controlled mechanical properties to be compatible with reinforcing bars complying with reinforcement of the relevant Grade in accordance with BS4449.

1.3 Conclusion

It is the opinion of CARES that Ancon MBT ET in the size range 10mm - 40mm and MBT Transition Couplers in the size range 12mm - 40mm are satisfactory for use within the limits stated in paragraph 1.1 when applied and used in accordance with the manufacturer’s instructions and the requirements of this certificate.

Lee Brankley

L. Brankley
 Chief Executive Officer
 March 2023

Electronic Copy www.carescertification.com



2 Technical Specification

Ancon MBT ET and MBT Transition type couplers are for use in connection of deformed steel reinforcing bars complying with BS4449 grades B500B and B500C as appropriate and thereby create structural continuity of the reinforcing system.

2.1 Ancon MBT ET Couplers

MBT ET couplers for connecting bars of same diameters are designed for use on concrete embedded rebar, repair or retrofit works.

MBT ET Couplers are easy to install and do not require bar end preparation to form threads, and bar rotation is not required for installation. The bar ends are supported within the coupler by two serrated saddles, and as the lockshear bolts are tightened, the conical ends embed themselves into the bar.

In all cases heavy duty sockets should be used. When the pre-determined tightening torque for the bolts is reached, the heads shear off leaving the top of the installed bolt slightly proud of the coupler. This provides an instant visual check of correct installation.

Note: Impact tools must not be used to tighten lockshear bolts.

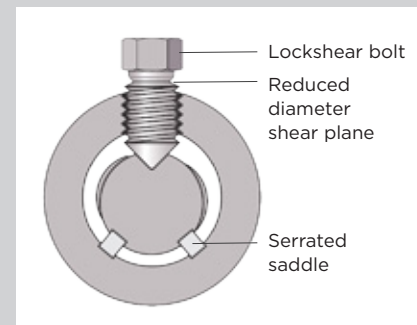

Section showing the embedment of the lockshear bolts and saddles into the bar and the shell of the coupler

MBT ET coupler

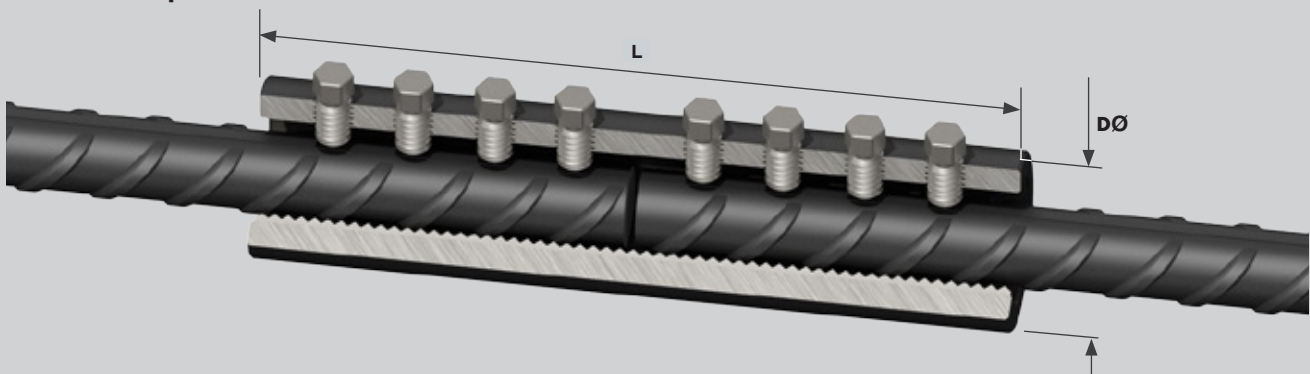

Coupler Size (mm)	Part No.	D (mm)	L (mm)	Bolt Size	Qty	Shear Torque (NM)	Torque Tolerance (NM)	Weight (kg)	Tensile Slip	Fatigue Class D
10	ET10	33.4 (+/- 0.33)	100 (+/- 2)	M10	4	55	-0/+20	0.52	B500B/B500C	B500B/B500C
12	ET12	33.4 (+/- 0.33)	140 (+/- 2)	M10	6	55	-0/+20	0.72	B500B/B500C	B500B/B500C
16	ET16	42.2(+/- 0.42)	160 (+/- 2)	M12	6	108	-0/+20	1.25	B500B/B500C	B500B/B500C
20	ET20	48.3 (+/- 0.48)	204 (+/- 2)	M12	8	108	-0/+20	1.96	B500B/B500C	B500B/B500C
25	ET25	54.0 (+/- 0.54)	258 (+/- 2)	M16	8	275	-0/+25	3.00	B500B/B500C	B500B/B500C
32	ET32	71.0 (+/- 0.71)	312 (+/- 2)	M16	10	360	-0/+25	6.50	B500B/B500C	B500B/B500C
40	ET40	81.0 (+/- 0.81)	484 (+/- 3)	M20	14	600	-0/+25	11.30	B500B/B500C	B500B/B500C

Table 1

2.2 Ancon MBT Transition Couplers

MBT Transition couplers for connecting bars of different diameters are designed for use on concrete embedded rebar, repair or retrofit works.

MBT Transition Couplers are easy to install and do not require bar end preparation to form threads, and bar rotation is not required for installation. The bar ends are supported within the coupler by two serrated saddles, and as the lockshear bolts are tightened, the conical ends embed themselves into the bar.

In all cases heavy duty sockets should be used. When the pre-determined tightening torque for the bolts is reached, the heads shear off leaving the top of the installed bolt slightly proud of the coupler. This provides an instant visual check of correct installation.

Note: Impact tools must not be used to tighten lockshear bolts.

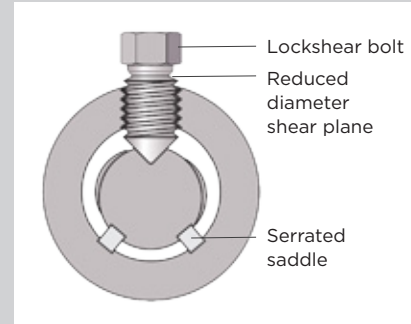

Section showing the embedment of the lockshear bolts and saddles into the bar and the shell of the coupler

MBT Transition coupler

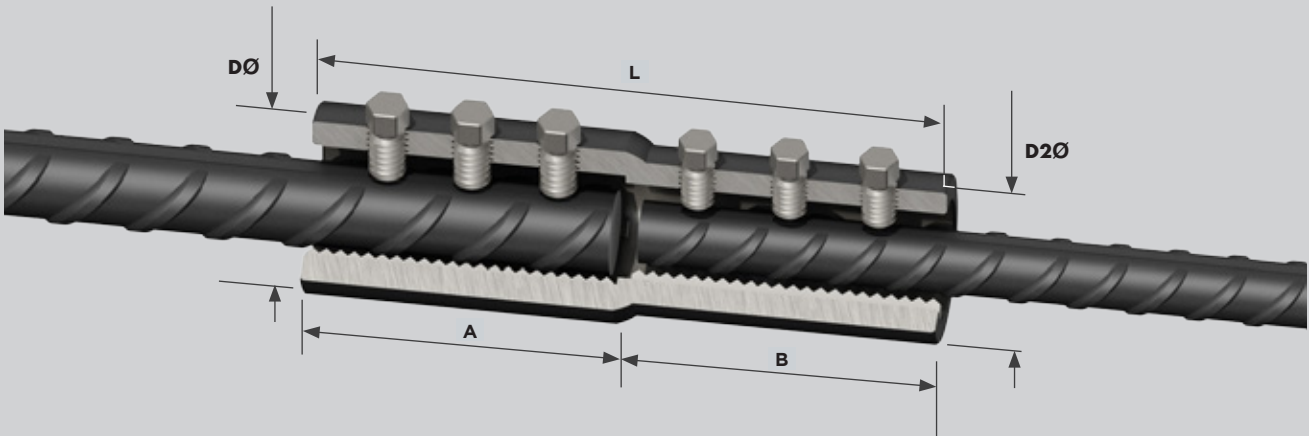

Coupler Size (mm)	Part No.	D (mm)	D2 (mm)	A:B (mm)	L (mm)	No. of bolts	Shear Torque (NM)	Torque Tolerance (NM)	Weight (kg)	Tensile Slip	Fatigue Class D
12/16	ET12/16	42.2	42.2	80:80	160	3:3	108/108	+/-20	1.30	B500B/B500C	B500B/B500C
12/20	ET12/20	33.4	48.3	80:70	150	3:3	55/108	+/-20	1.13	B500B/B500C	B500B/B500C
16/20	ET16/20	48.3	48.3	80:80	160	3:3	108/108	+/-20	1.56	B500B/B500C	B500B/B500C
16/25	ET16/25	42.2	54.0	75:80	155	3:2	108/275	+/-20_+/-25	1.51	B500B/B500C	B500B/B500C
20/25	ET20/25	54.0	54.0	90:90	180	3:3	275/275	+/-25	2.23	B500B/B500C	B500B/B500C
20/32	ET20/32	48.3	71.0	75:102	177	4:2	108/360	+/-20_+/-25	2.55	B500B/B500C	B500B/B500C
25/32	ET25/32	54.0	71.0	102:129	231	4:3	275/360	+/-25	3.70	B500B/B500C	B500B/B500C
32/40	ET32/40	71.0	81.0	178:157	335	5:5	360/525	+/-25	7.47	B500B/B500C	B500B/B500C

Table 2

3 Product Performance and Characteristics

Full destructive tests have been carried out to demonstrate compliance with the performance requirements defined in CARES Appendix TA1-A and Appendix TA1-B when used with reinforcing steel BS4449 grade B500B or B500C as appropriate:

CARES APPENDIX TA1-A and TA1-B strength requirements

- Permanent deformation is less than 0.10mm after loading to $0.65f_y$ in tension with BS4449 grades B500B or B500C reinforcement.
- 99% characteristic tensile strength is greater than 540MPa with B500B reinforcement 575MPa with B500C reinforcement.

4 Installation

Ancon MBT ET and MBT Transition Couplers must be correctly installed to ensure that the full working capacity can be achieved. The coupler should be complete with the correct number of bolts and the two serrated strip saddles in place inside the coupler. For correct installation, all the bolts must be tightened until the heads shear off.

MBT ET Coupler

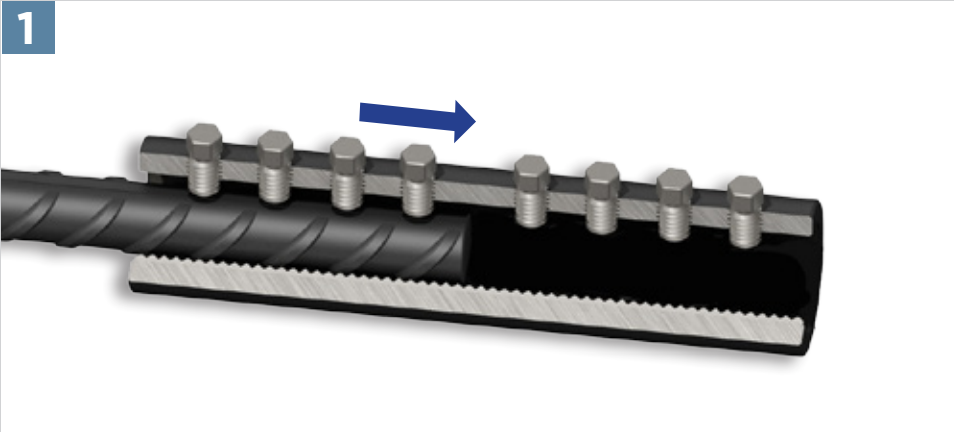

Place coupler over the end of the bar to half the coupler length +/- 6mm and finger tighten the lock shear bolts onto the bar. Check the alignment and make any necessary adjustments.

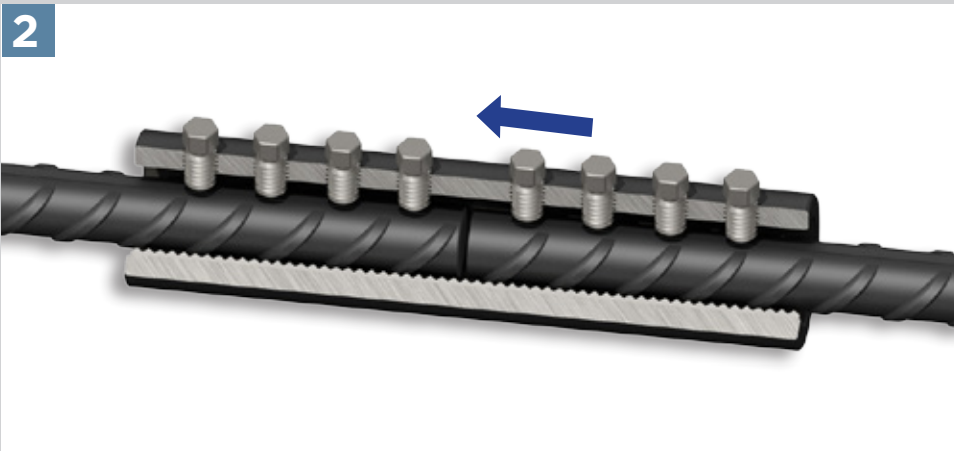

Place other bar end into the coupler until it pushes up against the first bar and finger tighten the remaining lock shear bolts. Check the alignment and make any adjustments. Finger tighten the lock shear bolts onto the bar.

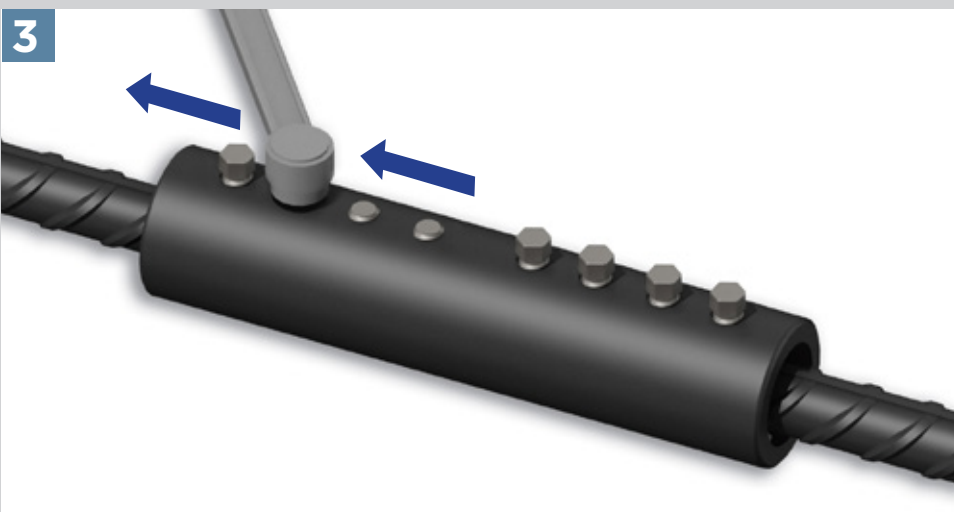

On one half of the coupler, starting from the centre and working outwards, partly tighten the lockshear bolts using either a ratchet wrench or a nut runner as appropriate. Do not use impact tools. Repeat again, this time fully tightening the lockshear bolts until the bolt heads shear off.

See table 2 for correct shear torque.

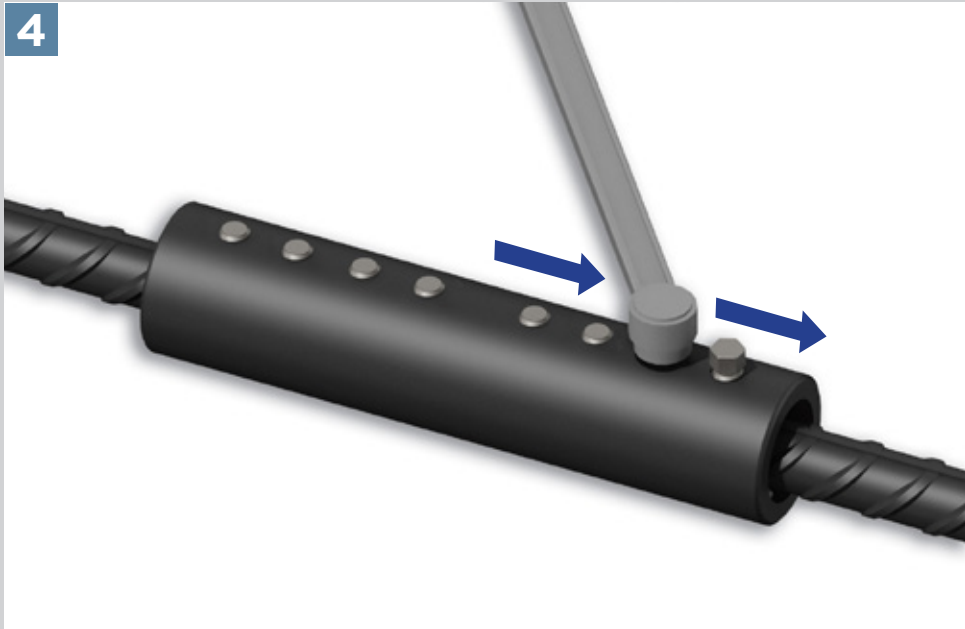

On the other half of the coupler, starting from the centre and working outwards, partly tighten the lockshear bolts using either a ratchet wrench or a nut runner as appropriate. Do not use impact tools. Repeat again, this time fully tightening the lockshear bolts until the bolt heads shear off.

See table 3 for correct shear torque.



Finished Coupler.

Coupler Size	10	12	16	20	25	32	40
Shear Bolts Torque	55	55	108	108	275	360	600
Shear Bolts Torque Tolerance	-0/+20	-0/+20	-0/+20	-0/+20	-0/+25	-0/+25	-0/+25

Table 3



Ancon Electric Wrenches

The smooth continuous action of the wrench prevents the early shearing of the lockshear bolts and damage to threads. The wrench is supplied with specially hardened heavy duty sockets.

MBT Transition Coupler

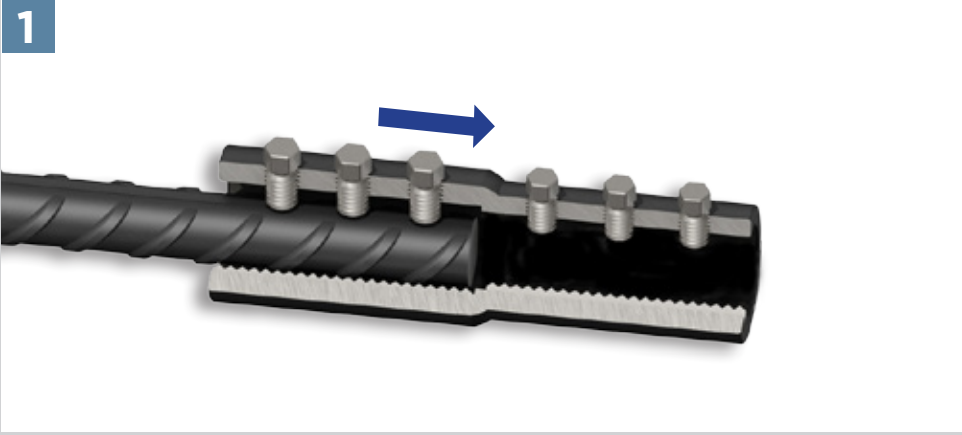

Place coupler over the end of the bar to half the coupler length +/- 6mm and finger tighten the lock shear bolts onto the bar. Check the alignment and make any necessary adjustments.

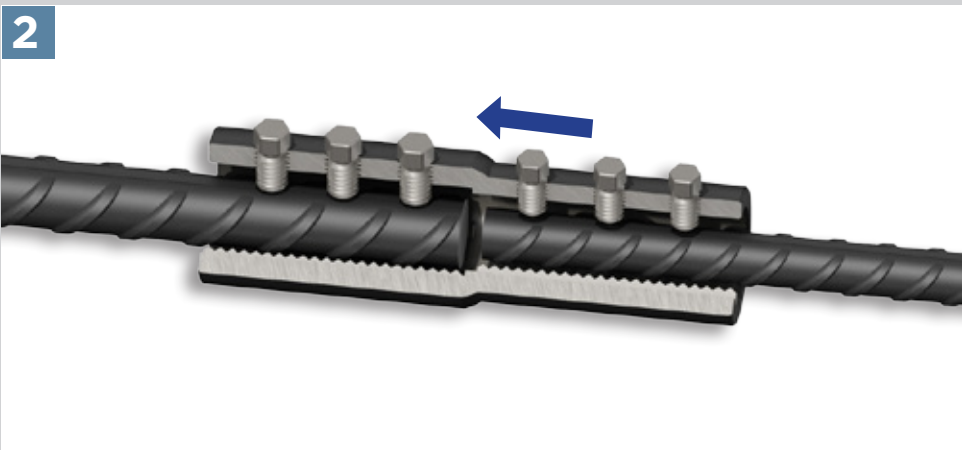

Place other bar end into the coupler until it pushes up against the first bar and finger tighten the remaining lock shear bolts. Check the alignment and make any adjustments. Finger tighten the lock shear bolts onto the bar.

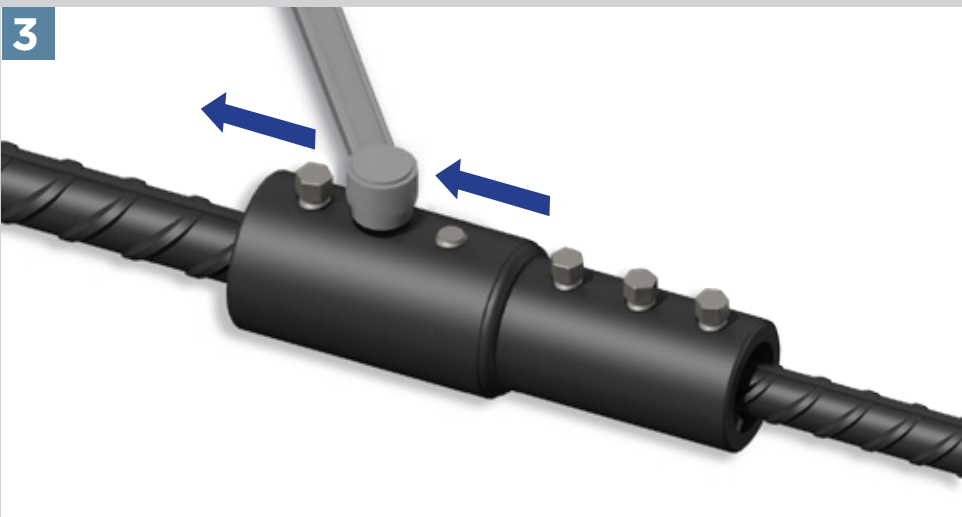

On one half of the coupler, starting from the centre and working outwards, partly tighten the lockshear bolts using either a ratchet wrench or a nut runner as appropriate. Do not use impact tools. Repeat again, this time fully tightening the lockshear bolts until the bolt heads shear off.

See table 4 for correct shear torque.

Electronic Copy www.carescertification.com

TECHNICAL APPROVAL 5083

0002

Validate with the CARES Cloud App

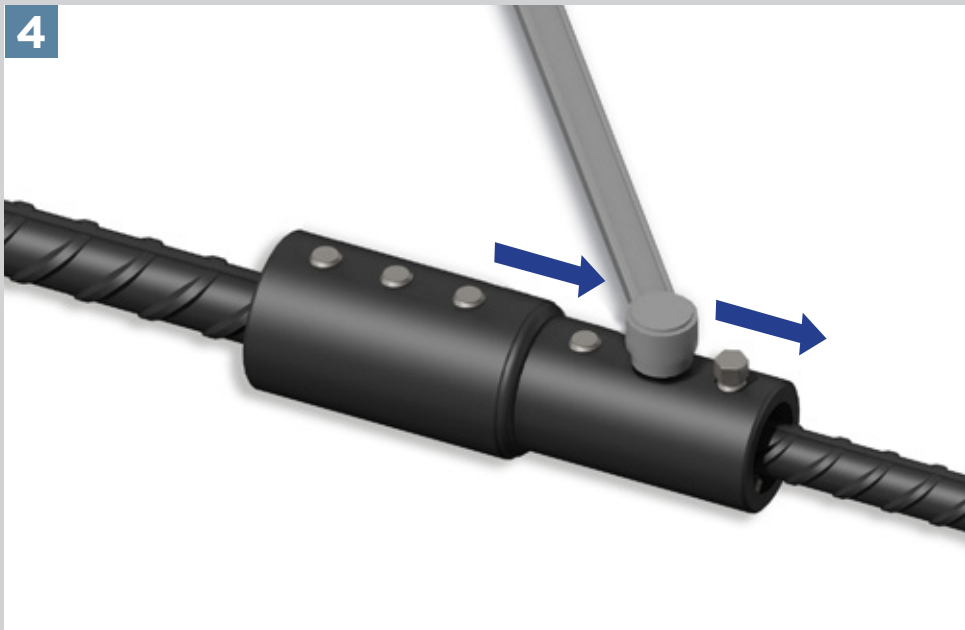

On the other half of the coupler, starting from the centre and working outwards, partly tighten the lockshear bolts using either a ratchet wrench or a nut runner as appropriate. Do not use impact tools. Repeat again, this time fully tightening the lockshear bolts until the bolt heads shear off.

See table 4 for correct shear torque.



Finished Coupler.

Coupler Size	12/16	12/20	16/20	16/25	20/25	20/32	25/32	32/40
Shear Bolts Torque	108/108	55/108	108/108	108/275	275/275	108/360	275/360	360/525
Shear Bolts Torque Tolerance	+/-20	+/-20	+/-20	+/-20_+/-25	+/-25	+/-20_+/-25	+/-25	+/-25

Table 4



Ancon Electric Wrenches

The smooth continuous action of the wrench prevents the early shearing of the lockshear bolts and damage to threads. The wrench is supplied with specially hardened heavy duty sockets.

5 Safety Considerations

Ancon MBT ET and MBT Transition Couplers are generally supplied in heavy duty plastic wrap, packed in robust wooden crates. Couplers in heavy duty plastic wrap are less than 25 kgs and may be handled manually with care. Heavier cases (wooden crates) require the use of mechanical handling equipment. Protective gloves should be used when installing the couplers.

6 Product Testing and Evaluation

Ancon MBT ET and MBT Transition Couplers have been tested to satisfy the requirements of CARES Appendix TA1-A and TA1-B for Couplers with reinforcing bars to BS4449 grades B500B and B500C as detailed in table 1. The testing comprised the following elements:

- Tensile Strength
- Permanent deformation in tension as detailed in table 1
- High cycle fatigue (Class D)

7 Quality Assurance

Ancon MBT ET and MBT Transition Couplers are produced under an EN ISO 9001 quality management system certified by CARES. The quality management system scheme monitors the production of the couplers and ensures that materials and geometry remain within the limits of this technical approval.

The products are also subject to a programme of periodic testing.



8 Building Regulations

8.1 The Building Regulations (England and Wales)

Structure, Approved Document A

Ancon MBT ET and MBT Transition Couplers, when used in EC2 based designs using the data contained within this technical approval, satisfy the relevant requirements of The Building Regulations (England and Wales), Approved Document A.

Materials and Workmanship, Approved Document

This technical approval gives assurance that the Ancon MBT ET and MBT Transition Couplers comply with the material requirements of EC2.

8.2 The Building Regulations (Northern Ireland)

Materials and Workmanship

This technical approval gives assurance that Ancon MBT ET and MBT Transition Couplers comply with the material requirements of EC2 by virtue of regulation 23, *Deemed to satisfy provisions regarding the fitness of materials and workmanship*.

8.3 The Building Standards (Scotland)

Fitness of Materials

This technical approval gives assurance that Ancon MBT ET and MBT Transition Couplers comply with the material requirements of EC2 by virtue of *Clause 0.8*.

Structure

Ancon MBT ET and MBT Transition Couplers, when used in EC2 based designs using the data contained within this technical approval, satisfy the requirements of *The Building Standards (Scotland) clause 1*.

8.4 MHCW Volume 1 Specification for Highway Works, Series 1700 Structural Concrete

This technical approval gives assurance that Ancon MBT ET and MBT Transition Couplers with the requirements of *Clause 1716. Reinforcement - Laps and Joints*.

9 References

- BS 4449: 2005: Steel for the reinforcement of concrete - Weldable reinforcing steel - Bar, coil and decoiled product - Specification.
- BS 8597 :2015: Steels for the reinforcement of concrete - Reinforcement couplers.
- BS8110: Part 1: 1997: Structural Use of Concrete, Code of Practice for Design and Construction.
- BS EN 1992-1-1:2004 Eurocode 2 Design of concrete structures - General rules for buildings.
- BS EN ISO 9001: Quality management systems - Requirements.
- CARES Appendix TA1-A: Quality and Operations Schedule for the Technical Approval of Couplers for Reinforcing Steel for use in Structures and Structural Elements designed in accordance with the Fatigue Requirements of Structural Eurocodes.
- CARES Appendix TA1-B: Quality and Operations Schedule for the Technical Approval of Couplers for Reinforcing Steel and Reinforcement Anchors for Static Loading in Tension or Tension and Compression.
- Manual of Contract Documents for Highways Works, Volume 1 Specification for Highways Works, Series 1700 Structural Concrete. (Amended March 2020).



10 Conditions

1. The quality of the materials and method of manufacture have been examined by CARES and found to be satisfactory. This technical approval will remain valid provided that:
 - a) The product design and specification are unchanged.
 - b) The materials, method of manufacture and location are unchanged.
 - c) The manufacturer complies with CARES regulations for Technical Approvals.
 - d) The manufacturer holds a valid CARES Certificate of Product Assessment.
 - e) The product is installed and used as described in this report.
2. CARES make no representation as to the presence or absence of patent rights subsisting in the product and/or the legal right of Leviat to market the product.
3. Any references to standards, codes or legislation are those which are in force at the date of this certificate.
4. Any recommendations relating to the safe use of this product are the minimum standards required when the product is used. These requirements do not purport to satisfy the requirements of the Health and Safety at Work etc Act 1974 or any other relevant safety legislation.
5. CARES does not accept any responsibility for any loss or injury arising as a direct or indirect result of the use of this product.
6. This Technical Approval Report should be read in conjunction with CARES Certificate of Product Assessment No 5083. Confirmation that this technical approval is current can be obtained from CARES.



Electronic Copy www.carescertification.com

CARES

Pembroke House
21 Pembroke Road
Sevenoaks
Kent TN13 1XR

Phone: +44(0)1732 450000
E-mail: general@carescertification.com
www.carescertification.com



**Independent Product Assessments
for the Construction Industry**

Copyright CARES ©